

24Z-Meter Truck-Mounted Concrete Boom Pump

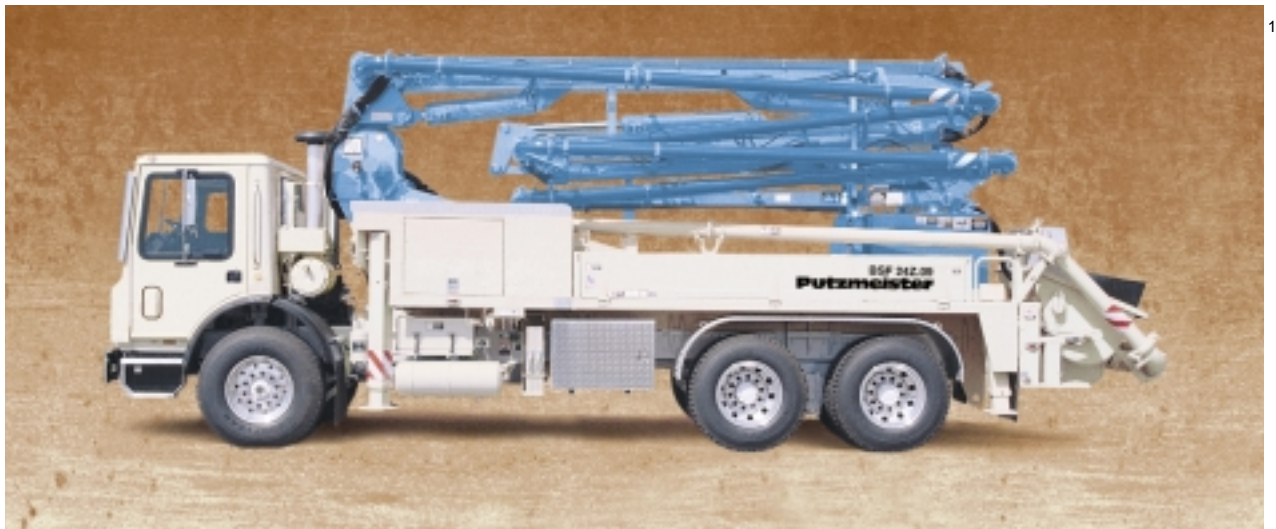

- **75 ft Vertical Reach**
- **Versatile 4-Section Multi-Z Boom**
- **Low 17 ft 1 in (5.20m) Unfolding Height**
- **Short Overall Length Without Overhang**
- **Fully Hydraulic Diagonal Outriggers**
- **Free Flow Hydraulics**

Boom The very compact Putzmeister 24Z-Meter truck-mounted concrete boom pump is designed with both versatility and affordability in mind. Attaining up to 75 ft heights, this unit features a 4-section Multi-Z boom for added maneuverability and a low 17 ft 1 in (5.2m) unfolding height. Standard fold down side panels offer additional convenience. Plus, engineered for an affordable two-axle truck, this model also provides a short overall length without overhang for expedient road travel.

Delivery Line The boom is equipped with a 5 in delivery line mounted in easy lift-out brackets for simple delivery line replacement. Standardized elbows and straight pipe sections are used for common component availability and easy replacement.

Pedestal The box-type construction of the pedestal is mounted to the subframe both at its base and via diagonal braces, which serve to spread the load over the largest possible area for better rigidity. The boom pedestal includes a rack and pinion slewing system for reduced maintenance costs and access openings to simplify changing the turret pipe. It also incorporates a hydraulic oil tank for improved weight distribution as well as a tool box for convenience. Double suction filters with indicator gauges are located in the pedestal for easy access, and a condensation trap is found in the tank to collect water. Two spacious 13 ft (4m) long decks allow convenient storage of pipe and hoses with convenient fold down side panels as standard equipment.

Radio Remote Controls Fully proportional HBC radio remote controls are standard for smooth and precise positioning of the boom. Additionally, the unit comes with a backup cable remote box with 130 ft (40m) cable for all boom and pump functions.

Outriggers All outrigger functions are fully hydraulic with integral cylinders. Front outriggers diagonally telescope and extend down, allowing for a smaller outrigger footprint and easier setup in tight areas. Rear outriggers extend down only. Wooden outrigger pads (4) with two side compartments are included with each unit.

Clean Out A 406 psi (28 bar) hydraulically-driven water pump with a 185 gallon (700L) water tank make clean out easy.

Concrete Pump With the same setup, only Putzmeister has the technology to offer both 117 yd³/hr output and provide 1015 psi concrete pressure (on the rod side).^{*} With competitive designs, you have to decide if you want either high pressure or high volume. Key features include a free flow hydraulic system for smooth controllable pumping as well as hard-chromed concrete cylinders and automatic lubrication of the concrete pistons for long service life. This pump has a fully adjustable volume control which allows very slow pumping while retaining full concrete pressure and boom speed.

^{*}Refers to .09 pump. Dependent on the application, the .12L pump (with long stroke cylinder) can handle the job - rated at 142 yd³/hr and 1015 psi concrete pressure (on the rod side).

S-Valve Ideal for high pressure applications, our hard faced S-Valve with gradual 8 in to 7 in (200 to 180mm) reduction is designed to handle extremely harsh concrete mixes. A thick-walled valve construction, exclusive Putzmeister hard-chromed concrete cylinders and multi-piece piston cup design provide longer lasting

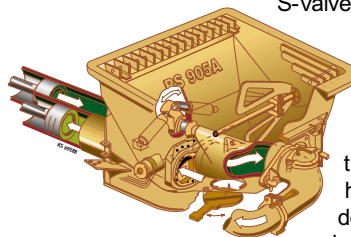

Hopper With a large 19.4 cu ft (550L) capacity, this **EZ Clean Out RS 905A** hopper features a remixer, vibrator and splash guards as standard. A low 51 in (1295mm) hopper height allows easy discharging from a mixer truck.

Specifications

24Z-Meter Concrete Pump

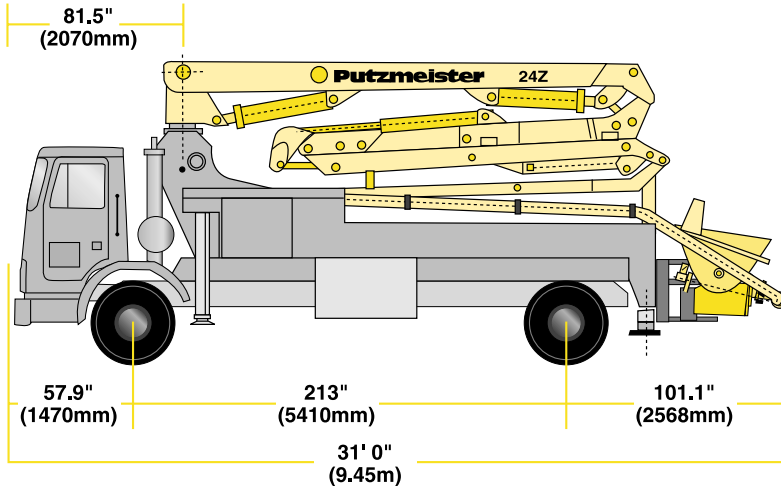

Truck-Mounted Specifications

Based on Model Volvo WX42

Length	31' 0"	(9.45m)
Width	8' 2"	(2.50m)
Height	12' 4"	(3.76m)
Wheelbase	213"	(5410mm)
Front axle weight	18,900 lbs	(8,573kg)
Rear axle weight	19,100 lbs	(8,663kg)
Approx total weight	38,000 lbs	(17,236kg)

Weights are approximate and include pump, boom, truck, full hydraulic oil, driver and some fuel. Varies with options selected.

Dimensions will vary with different truck makes, models and specifications.

Model illustrated on 2-Axle Truck;
3-Axle Chassis also available.

Boom Specifications • Multi-Z Design

Height & Reach

Vertical reach	74'8"	(22.76m)
Horizontal reach	62'9"	(19.13m)
Reach from front of truck*	55'6"	(16.92m)
Reach depth	43'5"	(13.23m)
Unfolding height	17'1"	(5.20m)

4-Section Boom

1st section articulation	90°
2nd section articulation	180°
3rd section articulation	260°
4th section articulation	260°
1st section length	19'0" (5.80m)
2nd section length	14'3" (4.35m)
3rd section length	14'9" (4.50m)
4th section length	14'9" (4.50m)

General Specs

Pipeline size (ID) metric ends with couplings	5" (125mm)
Rotation	365°
End hose-length (heavy duty)	10' (3m)
End hose-diameter	5" (125mm)
Outrigger spread L-R—front telescopic diagonal	17'9" (5.40m)
Outrigger spread L-R—rear down only	8'2" (2.50m)

Pump Specifications

24Z.09

24Z.12L

Output-	rod side	117 yd ³ /hr (90m ³ /hr)	142 yd ³ /hr (109m ³ /hr)
	piston side	78 yd ³ /hr (60m ³ /hr)	85 yd ³ /hr (65m ³ /hr)
Pressure-	rod side	1015 psi (70 bar)	1015 psi (70 bar)
	piston side	1537 psi* (106 bar)*	1624 psi* (112 bar)*
Concrete cylinder diameter		8" (200mm)	9" (230mm)
Stroke length		55" (1400mm)	83" (2100mm)
Max strokes per minute-			
	rod side	36	21
	piston side	25	13
Volume control		0-Full	0-Full
Vibrator		Standard	Standard
Hard chromed concrete cylinders		Standard	Standard
Hydraulic system		Free Flow	Free Flow
Hydraulic system pressure		5075 psi (350 bar)	5075 psi (350 bar)
Differential cylinder diameter		4.3" (110mm)	5.1" (130mm)
Rod diameter		2.5" (63mm)	3.1" (80mm)
Maximum size aggregate		2.5" (63mm)	2.5" (63mm)
Water Tank		185 gal (700L)	185 gal (700L)

Maximum theoretical values listed.

* Applies to units mounted on Volvo WX42

• Standard delivery line system rated at max line pressure of 1233 psi (85 bar)

Right to make technical amendments reserved.

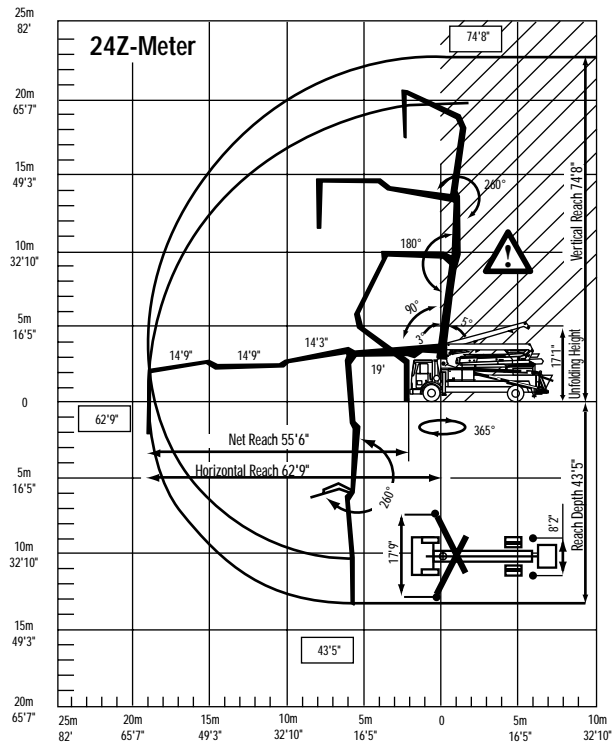

End hose not to be operated in caution area.



Putzmeister America
1733 90th Street
Sturtevant
Wisconsin 53177 USA

Telephone (262) 886-3200
(800) 884-7210
Facsimile (262) 884-6338
www.putzmeister.com