

46X-Meter Truck-Mounted Concrete Boom Pump



- **148 ft Vertical Reach**
- **Special Telescopic Diagonal X-Outrigger Design for Quicker Setup**
- **Induction Hardened 5" Delivery Line – All Sections**
- **High Volume Outputs and High Pressures**
- **Free Flow Hydraulics**
- **Overall Length Less Than 40 ft**

Boom The Putzmeister 46X-Meter truck-mounted concrete boom pump is the first and only unit in the 150 ft class to feature a compact telescopic diagonal X-outrigger design for quicker and easier setup in the tightest of areas. Plus, this highly versatile 4-section roll and fold boom is mounted on a four-axle chassis for enhanced maneuverability.

Delivery Line The boom is equipped with a 5 in induction hardened delivery line mounted in easy lift-out brackets for simple delivery line replacement. Standardized elbows and straight pipe sections are used for common component availability and easy replacement.

Pedestal The fully integrated pedestal design of the Putzmeister 46X absorbs all forces as outriggers and boom are within one structural element. This design results in less twist, reduced forces transferred to the truck frame, a small outrigger footprint, low overall weight and quick setup. The boom pedestal includes a rotation bearing and access openings to simplify changing the turret pipe. It also incorporates a hydraulic oil tank for improved weight distribution. Triple suction filters with indicator gauges are located in the pedestal for easy access, and a condensation trap is found in the tank to collect water. Two spacious 10.5 ft long decks allow convenient storage of pipe and hoses.

Outriggers The fully hydraulic telescopic diagonal X-outrigger design allows for quick and easy setup on congested job sites. Compact in width, the front double-acting outriggers diagonally telescope while rear ones swing out. Aluminum outrigger pads (4) with two side compartments are included with each unit.

Radio Remote Controls Fully proportional frequency hopping HBC radio remote controls are standard for smooth and precise positioning of the boom. Additionally, the unit comes with a backup cable remote box with 130 ft (40m) cable for all boom and pump functions.

Clean Out A 406 psi (28 bar) hydraulically-driven water pump with a 185 gallon (700L) water supply make clean out easy.

Concrete Pump With the same setup, only Putzmeister has the technology to offer both 260 yd³/hr output and provide 1233 psi concrete pressure with its .20H pump on the piston side (or 210 yd³/hr output and 1233 psi with its .16H pump - rod side). With competitive designs, you have to decide if you want either high pressure or high volume. Key features include a free flow hydraulic system for smooth controllable pumping as well as hard-chromed concrete cylinders and automatic lubrication of the concrete pistons for long service life. This pump has a fully adjustable volume control which allows very slow pumping while retaining full concrete pressure and boom speed.

S-Valve Ideal for high pressure applications, our hard-faced "Big Mouth" S-Valve with gradual 9 in to 7 in (230 to 180mm) reduction is designed to handle extremely harsh concrete mixes. A thick-walled valve construction, exclusive Putzmeister hard-chromed concrete cylinders and a multi-piece piston cup design all add up to longer pump performance.

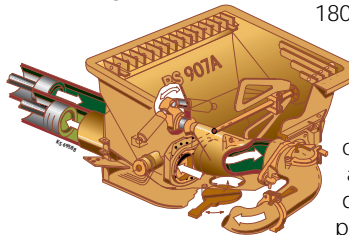

Hopper With a larger 19.4 cu ft (550L) capacity, this **E-Z Clean Out** RS 907A hopper features hard-faced remixer paddles, vibrator and a special hinged splash guard. Besides protecting the unit from splattering during pumping, this unique design conveniently folds down and latches to cover the hopper during transit. Additionally our low hopper height allows for easy discharge from mixer trucks.

Specifications

46X-Meter Concrete Pump

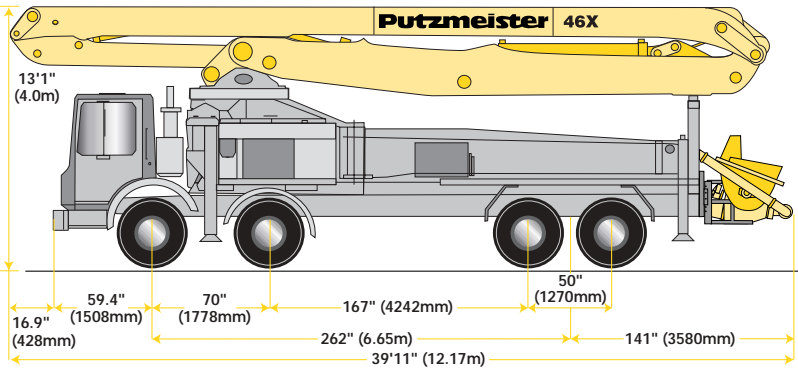

Truck-Mounted Specifications

Based on Model Mack MR 688S
with .16H pump cell.

Length	39'11"	(12.17m)
Width	8'2"	(2.50m)
Height	13'1"	(4.00m)
Wheelbase	262"	(6655mm)
Front axle weight*	39,243 lbs	(17,816kg)
Rear axle weight*	39,229 lbs	(17,810kg)
Approx total weight*	78,472 lbs	(35,626kg)

Weights are approximate and include pump, boom, truck, full hydraulic oil, driver and some fuel. Varies with options selected.

Dimensions will vary with different truck makes, models and specifications.

Boom Specifications • Roll and Fold Design

Height & Reach

Vertical reach	148'4"	(45.20m)
Horizontal reach	136'2"	(41.50m)
Reach from front of truck*	126'0"	(38.43m)
Reach depth	109'3"	(33.32m)
Unfolding height	40'4"	(12.30m)

4-Section Boom

1st section articulation	170°
2nd section articulation	177°
3rd section articulation	180°
4th section articulation	213°
1st section length	25'3" (7.70m)
2nd section length	37'1" (11.30m)
3rd section length	37'1" (11.30m)
4th section length	36'9" (11.20m)

General Specs

Pipeline size (ID) metric ends	5"	(125mm)
with couplings	5.5"	(140mm)
Rotation	365°	
End hose-length (heavy duty)	10'	(3m)
End hose-diameter	5"	(125mm)
Outrigger spread L-R-front telescopic diagonal	26'3"	(8.00m)
Outrigger spread L-R-rear swing-out	29'6"	(9.00m)

Pump Specifications

	46X.16H	46X.20H
Output- rod side	210 yd ³ /hr (160m ³ /hr)	—
piston side	146 yd ³ /hr (112m ³ /hr)	260 yd ³ /hr (200m ³ /hr)
Pressure- rod side	1233 psi (85 bar)	—
piston side	1885 psi (130 bar)*	1233 psi (85 bar)*
Concrete cylinder diameter	9" (230mm)	11" (280mm)
Stroke length	83" (2100mm)	83" (2100mm)
Max strokes per minute-		
rod side	31	—
piston side	21	26
Volume control	0-Full	0-Full
Vibrator	Standard	Standard
Hard chromed concrete cylinders	Standard	Standard
Hydraulic system	Free Flow	Free Flow
Hydraulic system pressure	5075 psi (350 bar)	5075 psi (350 bar)
Differential cylinder diameter	5.5" (140mm)	5.5" (140mm)
Rod diameter	3.1" (80mm)	3.1" (80mm)
Maximum size aggregate	2.5" (63mm)	2.5" (63mm)
Water tank - pedestal	40 gal (150L)	40 gal (150L)
- outrigger	145 gal (550L)	145 gal (550L)

Maximum theoretical values listed.

* Applies to units mounted on PMA stock truck-Mack MR 688S

• Standard delivery line system rated at max line pressure of 1233 psi (85 bar)

Right to make technical amendments reserved.

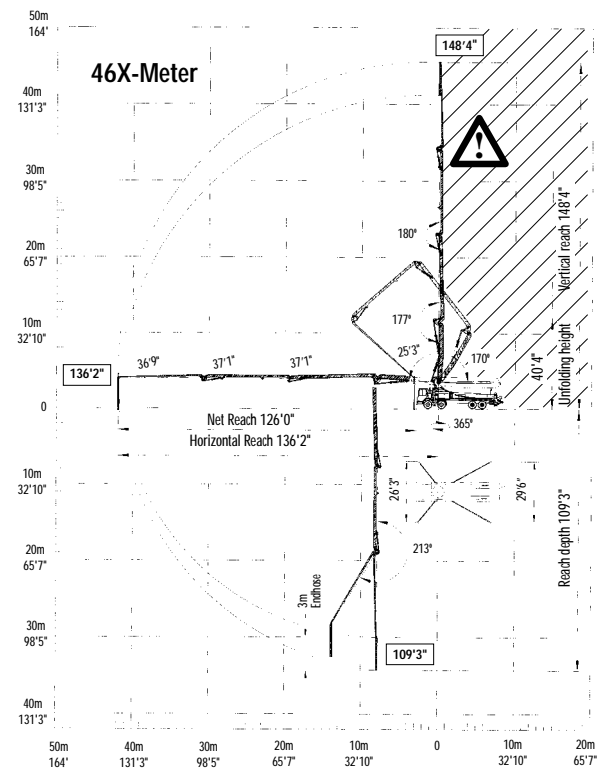

! End hose not to be operated in caution area.



Putzmeister America
1733 90th Street
Sturtevant
Wisconsin 53177 USA

Telephone (262) 886-3200
(800) 884-7210
Facsimile (262) 884-6338
www.putzmeister.com